

Bourdon Tube Pressure Gauges Model 212.20, Industrial Series

WIKA Data Sheet PM 02.01



Applications

- Sturdy industrial pressure gauge designed in compliance with the operational safety requirements of EN 837-1, BS 1780 and ASME B 40.1
- Reliable pressure gauge for the machine and plant construction industry as well as domestic technology
- For gaseous and liquid media that are not highly viscous or crystallising and will not attack copper alloy parts
- Proven in refrigeration technology

Special Features

- Long service life, robust
- Cost-effective and reliable
- To combine with WIKA diaphragm seals
- German Lloyd and Gosstandart approval
- Scale ranges up to 0 ... 600 bar

Description

Design

EN 837-1

Nominal size in mm

100, 160

Accuracy class

1.0

Scale ranges

0 ... 0.6 to 0 ... 600 bar
or all other equivalent vacuum or combined pressure and vacuum ranges



Bourdon Tube Pressure Gauge Model 212.20

Pressure limitation

Steady: full scale value
Fluctuating: 0.9 x full scale value
Short time: 1.3 x full scale value

Operating temperature

Ambient: -40 ... +60 °C
Medium: +80 °C maximum

Temperature effect

When the temperature of the measuring system deviates from the reference temperature (+20 °C):
max. $\pm 0.4 \%$ / 10 K of full scale value

Ingress protection

IP 54 per EN 60 529 / IEC 529

Standard version

Process connection

Cu-alloy,
lower mount (LM) or lower back mount (LBM)
G ½ B (male), 22 mm flats

Pressure element

< 100 bar: Cu-alloy, C-type
≥ 100 bar: stainless steel 316L, helical type

Movement

Cu-alloy, wear parts argantan

Dial

Aluminium, white, black lettering

Pointer

Aluminium, black

Case

Stainless steel

Window

Instrument glass

Bezel ring

Cam ring (bayonet type), stainless steel

Special versions

Refrigerant gauges

NS 100: featuring scales in °C for refrigerants R 744,
R 764, R 40, R 22 or R 134a

Options

- Other process connection
- NS 100: liquid filling (model 213.53, data sheet PM 02.12)
- NS 160: liquid filling (model 233.50, data sheet PM 02.02)
- Medium temperature to 100 °C with special soft solder
- Medium temperature to 200 °C (data sheet PM 02.02)
- Surface or panel mounting flange, stainless steel
- Panel mounting flange, stainless steel, polished
- Triangular bezel, stainless steel, polished, with clamp
- Alarm contacts (data sheet AC 08.01)

Dimensions in mm

Standard version

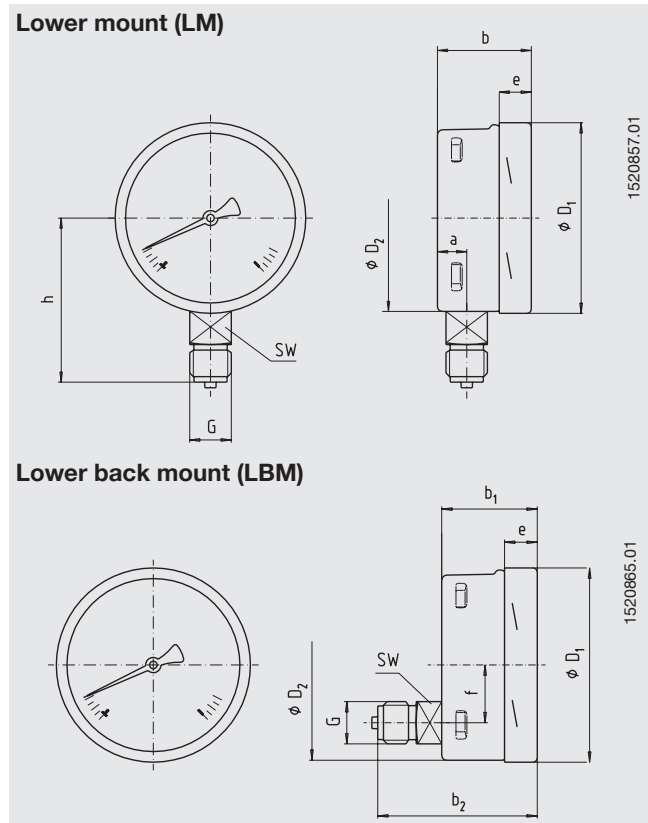

NS	Dimensions in mm										Weight in kg		
	a	b	b ₁	b ₂	D ₁	D ₂	e	f	G	h ± 1	SW		
100	15.5	49.5	49.5	83	101	100	17.5	30	G ½ B	87	22		0.60
160	15.5	49.5	49.5 ¹⁾	83 ¹⁾	161	160	17.5	50	G ½ B	118	22		1.10

Process connection per EN 837-1 / 7.3

1) Plus 16 mm with pressure ranges ≥ 100 bar

Ordering information

Model / Nominal size / Scale range / Connection size / Connection location / Options

Modifications may take place and materials specified may be replaced by others without prior notice.
Specifications and dimensions given in this leaflet represent the state of engineering at the time of printing.



WIKA Alexander Wiegand GmbH & Co. KG
Alexander-Wiegand-Straße 30
63911 Klingenberg/Germany
Tel. (+49) 9372/132-0
Fax (+49) 9372/132-406
E-mail info@wika.de
www.wika.de