

Capsule Pressure Gauges Model 612.20, Industrial Series

WIKA Data Sheet PM 06.02



Applications

- Robust design and ingress protection IP 54, suitable for outdoor use
- For gaseous, dry and non-aggressive media
- Medical, vacuum, environmental, laboratory technology, for contents measurement and filter monitoring

Special Features

- Zero adjustment in front
- Case made of stainless steel
- Special connection location on request
- Low scale ranges from 0 ... 6 mbar



Capsule Pressure Gauge Model 612.20

Description

Design

EN 837-3

Nominal size in mm

63, 100, 160

Accuracy class

1.6

Scale ranges

NS 63: 0 ... 25 mbar to 0 ... 600 mbar

NS 100: 0 ... 10 mbar to 0 ... 600 mbar

NS 160: 0 ... 6 mbar to 0 ... 600 mbar

or all other equivalent vacuum or combined pressure and vacuum ranges

Pressure limitation

Steady: full scale value

Fluctuating: 0.9 x full scale value

Operating temperature

Ambient: -20 ... +60 °C

Medium: +100 °C maximum

+80 °C max. (with NS 100 and 160 back mount)

Temperature effect

When the temperature of the measuring system deviates from the reference temperature (+20 °C):

max. $\pm 0.6\%$ / 10 K of full scale value

Ingress protection

IP 54 per EN 60 529 / IEC 529

Standard version

Process connection

Cu-alloy,
lower mount (LM) or lower back mount (LBM) 1)
NS 63: G ¼ B (male), 14 mm flats
NS 100, 160: G ½ B (male), 22 mm flats

Pressure element

Cu-alloy

Sealing

NBR

Movement

Cu-alloy

Zero adjustment

In front

Dial

Aluminium, white, black lettering

Pointer

Aluminium, black

Case

Stainless steel

Window

Instrument glass

Bezel ring

Cam ring (bayonet type), stainless steel

Options

- Other process connection
- Overpressure and vacuum safety at
scale ranges > 25 mbar: 10 x full scale value,
scale ranges ≤ 25 mbar: 3 x full scale value
- NS 100 and 160: Panel or surface mounting flange
- NS 100 and 160: Triangular bezel with clamp
- Switch contacts model 831 (data sheet AC 08.01)

Dimensions in mm

Standard version

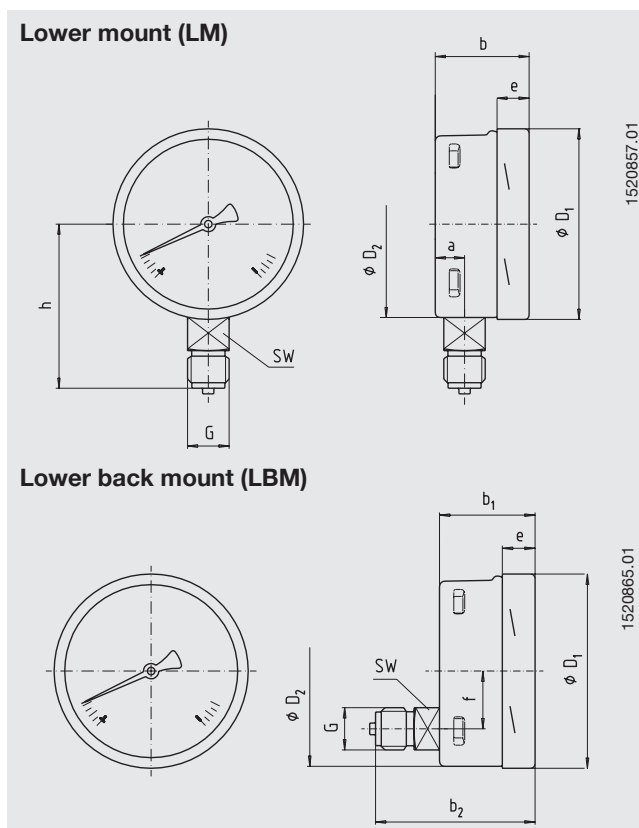

NS	Dimensions in mm										Weight in kg	
	a	b	b ₁	b ₂	D ₁	D ₂	e	f	G	h ± 1		
63	9.5	33	42	63	64	62	22	1)	G ¼ B	53	14	0.19
100	15.5	49.5	49.5	83	101	99	17.5	30	G ½ B	87	22	0.60
160	15.5	49.5	49.5	83	161	159	17.5	50	G ½ B	118	22	1.10

Process connection per EN 837-3 / 7.3

1) NS 63: Centre back mount (CBM)

Ordering information

Model / Nominal size / Scale range / Connection size / Connection location / Options

Modifications may take place and materials specified may be replaced by others without prior notice.
Specifications and dimensions given in this leaflet represent the state of engineering at the time of printing.



WIKAI Alexander Wiegand GmbH & Co. KG
Alexander-Wiegand-Straße 30
63911 Klingenberg/Germany
Tel. (+49) 9372/132-0
Fax (+49) 9372/132-406
E-mail info@wika.de
www.wika.de